

MFAC 14/34

High Impedance Differential Relays

Technical Manual

R8007G

Note: The technical manual for this device gives instructions for its installation, commissioning, and operation. However, the manual cannot cover all conceivable circumstances or include detailed information on all topics. In the event of questions or specific problems, do not take any action without proper authorization. Contact the appropriate Alstom Grid technical sales office and request the necessary information.

Any agreements, commitments, and legal relationships and any obligations on the part of Alstom Grid including settlements of warranties, result solely from the applicable purchase contract, which is not affected by the contents of the technical manual.

This device **MUST NOT** be modified. If any modification is made without the express permission of Alstom Grid, it will invalidate the warranty, and may render the product unsafe.

The Alstom Grid logo and any alternative version thereof are trademarks and service marks of Alstom Grid.

All trade names or trademarks mentioned herein whether registered or not, are the property of their owners.

This manual is provided for informational use only and is subject to change without notice.

© 2010, Alstom Grid. All rights reserved.

HANDLING OF ELECTRONIC EQUIPMENT

A person's normal movements can easily generate electrostatic potentials of several thousand volts. Discharge of these voltages into semiconductor devices when handling circuits can cause serious damage, which often may not be immediately apparent but the reliability of the circuit will have been reduced.

The electronic circuits of Alstom Grid products are immune to the relevant levels of electrostatic discharge when housed in their cases. Do not expose them to the risk of damage by withdrawing modules unnecessarily.

Each module incorporates the highest practicable protection for its semiconductor devices. However, if it becomes necessary to withdraw a module, the following precautions should be taken to preserve the high reliability and long life for which the equipment has been designed and manufactured.

1. Before removing a module, ensure that you are at the same electrostatic potential as the equipment by touching the case.
2. Handle the module by its front-plate, frame, or edges of the printed circuit board. Avoid touching the electronic components, printed circuit track or connectors.
3. Do not pass the module to any person without first ensuring that you are both at the same electrostatic potential. Shaking hands achieves equipotential.
4. Place the module on an antistatic surface, or on a conducting surface which is at the same potential as yourself.
5. Store or transport the module in a conductive bag.

More information on safe working procedures for all electronic equipment can be found in BS5783 and IEC 60147-0F.

If you are making measurements on the internal electronic circuitry of an equipment in service, it is preferable that you are earthed to the case with a conductive wrist strap.

Wrist straps should have a resistance to ground between 500k – 10M ohms. If a wrist strap is not available you should maintain regular contact with the case to prevent the build up of static. Instrumentation which may be used for making measurements should be earthed to the case whenever possible.

Alstom Grid strongly recommends that detailed investigations on the electronic circuitry, or modification work, should be carried out in a Special Handling Area such as described in BS5783 or IEC 60147-0F.

TYPES: MFAC 14
MFAC 34

CONTENTS

	SAFETY SECTION	5
1.	INSTALLATION	9
1.1	General	9
1.2	Unpacking	9
1.3	Storage	9
1.4	Site	9
2.	COMMISSIONING	10
2.1	Description of relay, calculation of setting and commissioning preliminaries	10
2.2	Instructions to ensure that the relay can be commissioned at the specific settings for the application	12
3.	MAINTENANCE	18
4.	MECHANICAL SETTINGS	18
4.1	General	18
4.2	Contact settings	18
4.3	Mechanical flag settings	18
5.	PROBLEM ANALYSIS	19
5.1	Failure to operate	19
5.2	Output contacts not changing state	19
6.	SPARES	20
7.	COMMISSIONING TEST RECORD	21
	REPAIR FORM	23

1. SAFETY SECTION

This Safety Section should be read before commencing any work on the equipment.

1.1 Health and safety

The information in the Safety Section of the product documentation is intended to ensure that products are properly installed and handled in order to maintain them in a safe condition. It is assumed that everyone who will be associated with the equipment will be familiar with the contents of the Safety Section.

1.2 Explanation of symbols and labels

The meaning of symbols and labels may be used on the equipment or in the product documentation, is given below.



Caution: refer to product documentation

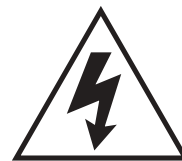

Caution: risk of electric shock



Protective/safety *earth terminal



Functional *earth terminal

Note: This symbol may also be used for a protective/safety earth terminal if that terminal is part of a terminal block or sub-assembly e.g. power supply.

*NOTE: THE TERM EARTH USED THROUGHOUT THE PRODUCT DOCUMENTATION IS THE DIRECT EQUIVALENT OF THE NORTH AMERICAN TERM GROUND.

2. INSTALLING, COMMISSIONING AND SERVICING



Equipment connections

Personnel undertaking installation, commissioning or servicing work on this equipment should be aware of the correct working procedures to ensure safety. The product documentation should be consulted before installing, commissioning or servicing the equipment.

Terminals exposed during installation, commissioning and maintenance may present a hazardous voltage unless the equipment is electrically isolated.

If there is unlocked access to the rear of the equipment, care should be taken by all personnel to avoid electrical shock or energy hazards.

Voltage and current connections should be made using insulated crimp terminations to ensure that terminal block insulation requirements are maintained for safety. To ensure that wires are correctly terminated, the correct crimp terminal and tool for the wire size should be used.

Before energising the equipment it must be earthed using the protective earth terminal, or the appropriate termination of the supply plug in the case of plug connected equipment. Omitting or disconnecting the equipment earth may cause a safety hazard.

The recommended minimum earth wire size is 2.5mm², unless otherwise stated in the technical data section of the product documentation.

Before energising the equipment, the following should be checked:

- Voltage rating and polarity;
- CT circuit rating and integrity of connections;
- Protective fuse rating;
- Integrity of earth connection (where applicable)
- Remove front plate plastic film protection
- Remove insulating strip from battery compartment

3. EQUIPMENT OPERATING CONDITIONS

The equipment should be operated within the specified electrical and environmental limits.

3.1 Current transformer circuits



Do not open the secondary circuit of a live CT since the high level voltage produced may be lethal to personnel and could damage insulation.

3.2 External resistors



Where external resistors are fitted to relays, these may present a risk of electric shock or burns, if touched.

3.3 Battery replacement



Where internal batteries are fitted they should be replaced with the recommended type and be installed with the correct polarity, to avoid possible damage to the equipment.

3.4 Insulation and dielectric strength testing



Insulation testing may leave capacitors charged up to a hazardous voltage. At the end of each part of the test, the voltage should be gradually reduced to zero, to discharge capacitors, before the test leads are disconnected.

3.5 Insertion of modules and pcb cards



These must not be inserted into or withdrawn from equipment whilst it is energised since this may result in damage.

3.6 Fibre optic communication



Where fibre optic communication devices are fitted, these should not be viewed directly. Optical power meters should be used to determine the operation or signal level of the device.

4. OLDER PRODUCTS

Electrical adjustments



Equipments which require direct physical adjustments to their operating mechanism to change current or voltage settings, should have the electrical power removed before making the change, to avoid any risk of electrical shock.

Mechanical adjustments



The electrical power to the relay contacts should be removed before checking any mechanical settings, to avoid any risk of electric shock.

Draw out case relays



Removal of the cover on equipment incorporating electromechanical operating elements, may expose hazardous live parts such as relay contacts.

Insertion and withdrawal of extender cards



When using an extender card, this should not be inserted or withdrawn from the equipment whilst it is energised. This is to avoid possible shock or damage hazards. Hazardous live voltages may be accessible on the extender card.

Insertion and withdrawal of heavy current test plugs



When using a heavy current test plug, CT shorting links must be in place before insertion or removal, to avoid potentially lethal voltages.

5. DECOMMISSIONING AND DISPOSAL



Decommissioning: The auxiliary supply circuit in the relay may include capacitors across the supply or to earth. To avoid electric shock or energy hazards, after completely isolating the supplies to the relay (both poles of any dc supply), the capacitors should be safely discharged via the external terminals prior to decommissioning.

Disposal: It is recommended that incineration and disposal to water courses is avoided. The product should be disposed of in a safe manner. Any products containing batteries should have them removed before disposal, taking precautions to avoid short circuits. Particular regulations within the country of operation, may apply to the disposal of lithium batteries.

6. TECHNICAL SPECIFICATIONS

Protective fuse rating

The recommended maximum rating of the external protective fuse for this equipment is 16A, Red Spot type or equivalent, unless otherwise stated in the technical data section of the product documentation.

Insulation class:	IEC 601010-1 : 1990/A2 : 2001 Class I EN 61010-1: 2001 Class I	This equipment requires a protective (safety) earth connection to ensure user safety.
Insulation Category (Overvoltage):	IEC 601010-1 : 1990/A2 : 1995 Category III EN 61010-1: 2001 Category III	Distribution level, fixed insulation. Equipment in this category is qualification tested at 5kV peak, 1.2/50 μ s, 500 Ω , 0.5J, between all supply circuits and earth and also between independent circuits.
Environment:	IEC 601010-1 : 1990/A2 : 1995 Pollution degree 2 EN 61010-1: 2001 Pollution degree 2	Compliance is demonstrated by reference to generic safety standards.
Product Safety:	72/23/EEC	Compliance with the European Commission Low Voltage Directive.
CE	EN 61010-1: 2001 EN 60950-1: 2002	Compliance is demonstrated by reference to generic safety standards.

Section 1. INSTALLATION

1.1 General

Protective relays, although generally of robust construction, require careful treatment prior to installation and a wise selection of site. By observing a few simple rules the possibility of premature failure is eliminated and a high degree of performance can be expected.

The relays are either despatched individually or as part of a panel/rack mounted assembly in cartons specifically designed to protect them from damage.

Relays should be examined immediately they are received to ensure that no damage has been sustained in transit. If damage due to rough handling is evident, a claim should be made immediately to the transport company concerned and the nearest Alstom Grid representative should be promptly notified. Relays which are supplied unmounted and not intended for immediate installation should be returned to their protective polythene bags.

1.2 Unpacking

Care must be taken when unpacking and installing the relays so that none of the parts are damaged or their settings altered and must at all times be handled by skilled persons only.

Relays should be examined for any wedges, clamps, or rubber bands necessary to secure moving parts to prevent damage during transit and these should be removed after installation and before commissioning.

Relays which have been removed from their cases should not be left in situations where they are exposed to dust or damp. This particularly applies to installations which are being carried out at the same time as constructional work.

1.3 Storage

If relays are not installed immediately upon receipt they should be stored in a place free from dust and moisture in their original cartons and where de-humidifier bags have been included in the packing they should be retained. The action of the de-humidifier crystals will be impaired if the bag has been exposed to damp ambient conditions and may be restored by gently heating the bag for about an hour, prior to replacing it in the carton.

Dust which collects on a carton may, on subsequent unpacking, find its way into the relay; in damp conditions the carton and packing may become impregnated with moisture and the de-humidifying agent will lose its efficiency.

The storage temperature range is -25° and $+70^{\circ}\text{C}$.

1.4 Site

The installation should be clean, dry and reasonably free from dust and excessive vibration. The site should preferably be well illuminated to facilitate inspection.

An outline diagram is normally supplied showing panel cut-outs and hole centres. For individually mounted relays these dimensions will also be found in Publication R6008.

Publication R7012 is a Parts Catalogue and Assembly Instructions. This document will be useful when individual relays are to be assembled as a composite rack or panel mounted assembly.

Publication R6001 is a leaflet on the modular integrated drawout system of protective relays.

Publication R6014 is a list of recommended suppliers for the pre-insulated connectors.

Section 2. COMMISSIONING

2.1 Description of relay, calculation of setting and commissioning preliminaries

2.1.1 Description of MFAC 14/MFAC 34

This is a voltage operated relay having seven equally spaced settings of 15–185 volts, 25–175 volts, 25–375 volts or 100–400 volts which may be selected by means of a plug bridge.

The relays may be used for any type of high impedance circulating current protection.

2.1.2 List of abbreviations.

I_E = Current transformer exciting current at relay setting voltage (referred to the CT secondary current)

I_F = Maximum value of primary through fault current for which protection must remain stable.

I_{FM} = Maximum value of primary fault current for internal fault.

I_P = Primary current for operation of protection.

I_R = Relay operating current.

I_{SH} = Current in shunt resistor at relay setting V_R .

N = Turns ratio of current transformer.

n = No. of current transformers in parallel with relay.

R_{CT} = Secondary resistance of current transformer.

R_L = Lead resistance between furthest current transformer and relay connection point.

R_R = Relay impedance.

R_{SH} = Value of shunt resistor.

V_F = The theoretical voltage which would be produced across the relay circuit under internal fault condition.

$$V_F = \frac{I_{FM}}{N} (R_{CT} + 2R_L + R_R)$$

V_K = Knee point voltage of current transformer.

V_P = Peak voltage across relay circuit under maximum internal fault conditions.

V_S = Minimum setting voltage. (calculated)

V_R = Relay setting voltage.

2.1.3 Calculation of relay setting.

The minimum setting voltage to ensure stability is

$$V_S \geq \frac{I_F}{N} (R_{CT} + 2R_L)$$

The relay plug setting voltage V_R must be set to the nearest tap above V_S .

The minimum knee point voltage must be

$$V_K \geq 2V_R$$

The operating current of the relay is 38mA, irrespective of tap selected, excluding the current drawn by the external metrosil. When a standard metrosil is included with the relay, the relay operating current including the metrosil is given in the table below. It must be appreciated that metrosils have large tolerances and these figures are given for guidance only.

a) Low range relay (5V steps)

Setting voltage V_R	15	50	75	100	125	150	175	185
Relay current I_R (mA) (including metrosil, C = 450)	38	38	39	42	46	55	72	81

b) Low range relay

Setting voltage V_R	25	50	75	100	125	150	175
Relay current I_R (mA) (including metrosil, C = 450)	19	19	20	23	27	36	53

c) High range relay

Setting voltage V_R	25	75	125	175	225	275	325
Relay current I_R (mA) (including metrosil, C = 900)	19	19	20	22	24	31	44

d) 100–400V version

Setting voltage V_R	100	150	200	250	300	350	400
Setting voltage I_R (mA) (including metrosil, C = 1100)	19	19	20	20	23	27	36

The primary current for operation is given by

$$I_P = N (I_R + nI_E)$$

If the resultant value of I_P is too low it may be increased by the addition of a shunt resistor R_{SH} to give a current of

$$I_{SH} = \frac{V_R}{R_{SH}}$$

The new increased value of primary current

$$I_P = N (I_R + nI_E + I_{SH})$$

External metrosils.

Each FAC relay is applied with an external metrosil which must be wired across the relay circuit. This provides a shunt circuit for high internal fault currents and prevents a high voltage being developed across the CT and relay circuits.

2.1.4 Commissioning preliminaries.

Inspection.

Carefully examine the module and case to see that no damage has occurred during transit. Check that the relay serial number on the module, case and cover are identical, and that the model number and rating information are correct.

Carefully remove any elastic bands/packing fitted for transportation purposes.

Carefully actuate the armature of each unit in turn with a small screwdriver/probe. Note that immediately after the point where any normally open contacts just make

there is a small further movement of the armature. This ensures that contact follow through and wiping action is present. On units fitted with hand reset flag indicators, check the flag is free to fall before, or just as, any normally open contacts touch.

Check that the external wiring is correct to the relevant relay diagram or scheme diagram. The relay diagram number appears inside the case.

Particular attention should be paid to the correct wiring and value of any external resistors indicated on the wiring diagram/relay rating information.

Note that shorting switches shown on the relay diagram are fitted internally across the relevant case terminals and close when the module is withdrawn. It is essential that such switches are fitted across all CT circuits.

If a test block type MMLG is provided, the connections should be checked to the scheme diagram, particularly that the supply connections are to the 'live' side of the test block (coloured orange) and with terminals allocated with odd numbers (1, 3, 5, 7, etc.).

Earthing.

Ensure that the case earthing connection above the rear terminal block, is used to connect the relay to a local earth bar.

Insulation.

The relay, and its associated wiring, may be insulation tested between:

- a) all electrically isolated circuits
- b) all circuits and earth

An electronic or brushless insulation tester should be used, having a dc voltage not exceeding 1000V. Accessible terminals of the same circuit should first be strapped together.

Deliberate circuit earthing links, removed for the tests, must subsequently be replaced.

Terminal allocation.

Terminals of the relay are normally allocated as below, but reference should always be made to the relevant diagram.

- a) Single pole relays

Normally open contacts 1, 3 and 2, 4.

AC current input – 27, 28.

An alternative version of the relay has additional normally open contacts connected to 5, 7 and 6, 8.

- b) Triple pole relays

Normally open contacts 1, 3 and 2, 4.

The contacts are normally connected in parallel for the three phases but a version of the relay having contacts brought out separately is available.

AC current inputs - 23, 24 : 25, 26 : 27, 28.

2.2 Instructions to ensure that the relay can be commissioned at the specific settings for the application

It is only necessary to check the relay at the setting on which it is to be used. The relay must not be used at any setting other than that for which the setting has been calculated.

2.2.1 Test equipment required

- 1 – Secondary injection test equipment capable of providing an ac voltage supply of up to at least 120% of the relay setting.
- 1 – Multifinger test plug type MMLB 01 for use with test block type MMLG if fitted.
- 1 – Miniature split plug type MMLB 03 to fit relay plug bridge.
- 3 – Calibrated multimeters 0–10 amp ac, 0–400 volt ac.
- 1 – Set primary injection testing equipment.

2.2.2 General

If the relay is wired through an MMLG test block it is recommended that all secondary injection tests should be carried out using this block.

Ensure that the main system current transformers are shorted before isolating the relay from the current transformers in preparation for secondary injection tests.

DANGER:

DO NOT OPEN CIRCUIT THE SECONDARY CIRCUIT OF A CURRENT TRANSFORMER SINCE THE HIGH VOLTAGE PRODUCED MAY BE LETHAL AND COULD DAMAGE INSULATION.

When type MMLG test block facilities are installed, it is important that the sockets in the type MMLB 01 test plug, which correspond to the current transformer secondary windings, are LINKED BEFORE THE TEST PLUG IS INSERTED INTO THE TEST BLOCK. Similarly, a MMLB 02 single finger test plug must be terminated with an ammeter BEFORE IT IS INSERTED to monitor CT secondary currents.

It is assumed that the initial preliminary checks have been carried out.

2.2.3 Relay CT shorting switches

With the relay removed from its case, check electrically that the CT shorting switch is closed.

2.2.4 Secondary injection testing

Connect the circuit as shown in Figure 1 and ensure that the current transformer primary is open circuit and that if any earthing connections are fitted, they do not short out the primaries of any current transformers.

Increase the voltage until the relay just operates.

Note the current in the relay (this can be done using the miniature split plug inserted into the appropriate position of the plug bridge connected to an ammeter). It should be approximately 38mA at setting.

Note also the voltage at which the relay operates which should correspond to the setting V_R of the relay with a tolerance of $\pm 10\%$. The total secondary current for operation will be given on ammeter A1. This test should be repeated for each pole of the relay.

Drop off/Pick up ratio.

Check that this ratio is greater than 50%.

2.2.5 Primary injection testing

It is essential that primary injection testing is carried out to prove the correct polarity of current transformers.

Before commencing any primary injection testing it is essential to ensure that the circuit is dead, isolated from the remainder of the system and that only those earth connections associated with the primary test equipment are in position.

2.2.6 Primary fault setting

The primary fault setting of any balanced scheme can be checked using the circuit shown in Figure 2. The primary current is injected into each current transformer in turn and increased until the relay operates. The voltage at which the relay operates should be within $\pm 10\%$ of the relay setting voltage V_R . The primary current for operation and relay current should be noted.

In the case of machine protection similar tests must be carried out by injecting first into each current transformer in turn to determine the primary fault setting.

For large machines the machine itself can be used to provide the fault current to check the primary fault setting as shown in Figure 5. The machine should be run up to speed with no excitation. The excitation should then be increased until the relays have all operated. The primary current, relay current and relay voltage should be noted as each relay operates.

2.2.7 Through fault stability

With any form of unbalanced protection it is necessary to check that the current transformers are correctly connected. For this purpose with a restricted earth fault scheme the circuit shown in Figure 3 may be used. During this test it is necessary to measure the spill current in the relay circuit and short out the relay and stabilising resistor (if fitted). The current is increased up to as near full load as possible and the spill current noted. The spill current should be very low, only a few milliamps if the connections are correct. A high reading (twice the injected current, referred through the current transformer ratio) indicates that one of the current transformers is reversed.

Injection should be carried out through each phase to neutral.

Where primary injection is not practicable in the case of restricted earth fault protection on a transformer it may be possible to check stability by means of back energising the transformer from a low voltage (415V) supply as shown in Figure 4.

In the case of machine protection, similar stability tests must be carried out by injecting into one and out of another current transformer connected on the same phase.

For large machines, the machine itself can be used to provide the fault current, but the short circuit must now be fitted as shown in Figure 6. The machine should be run up to normal speed and the excitation increased until the primary current is approximately full load, when the spill current should be checked.

All other types of balanced protection should be tested in a similar manner.

At the conclusion of the tests ensure that all connections are correctly restored and any shorting connections removed.

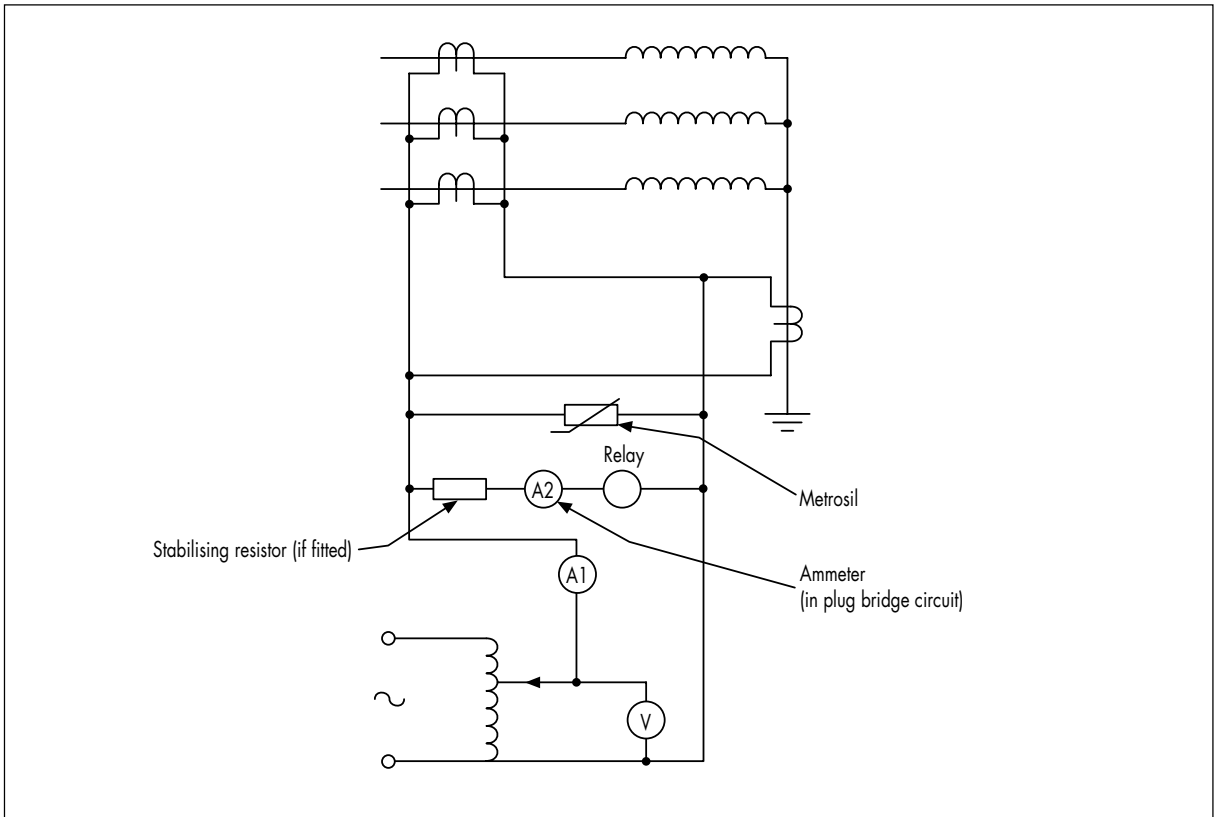

Figure 1 Secondary injection of relay to check secondary operating current, setting voltage and relay operating current.

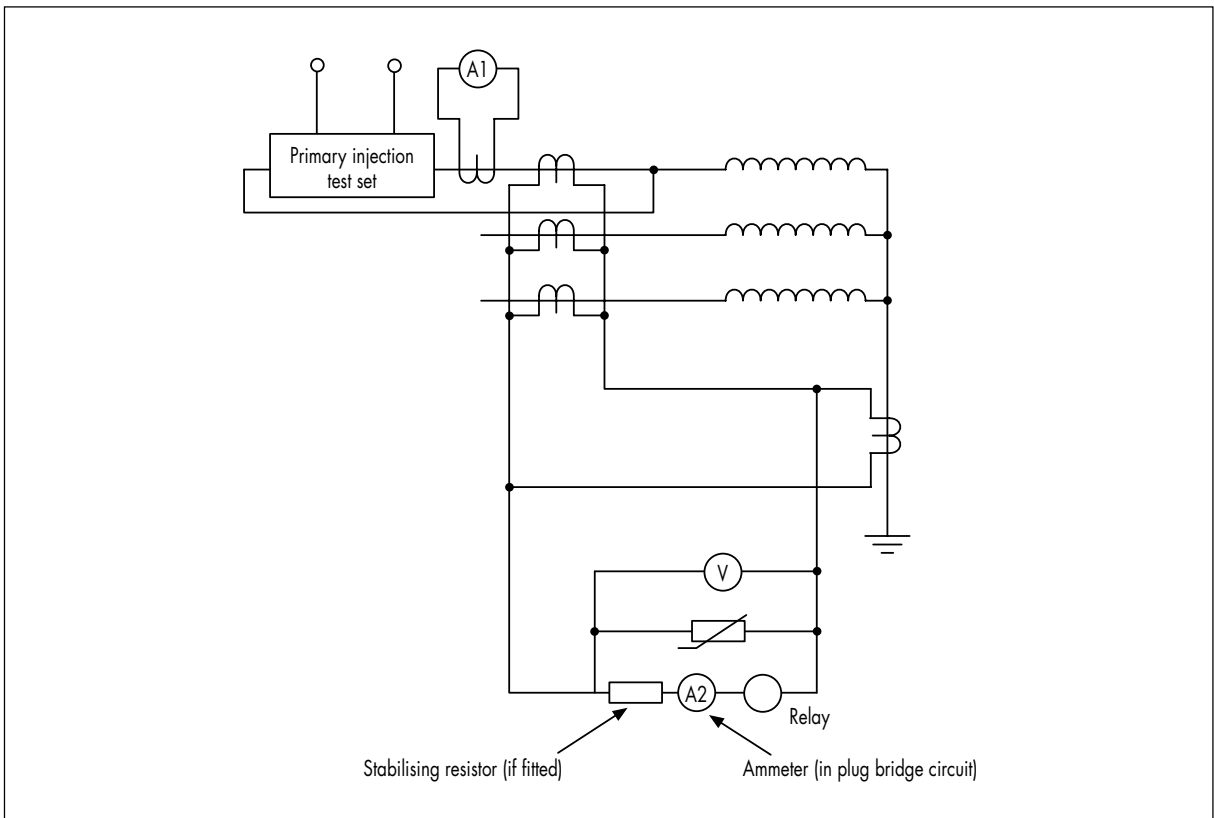

Figure 2 Sensitivity check of restricted earth fault scheme by primary injection.

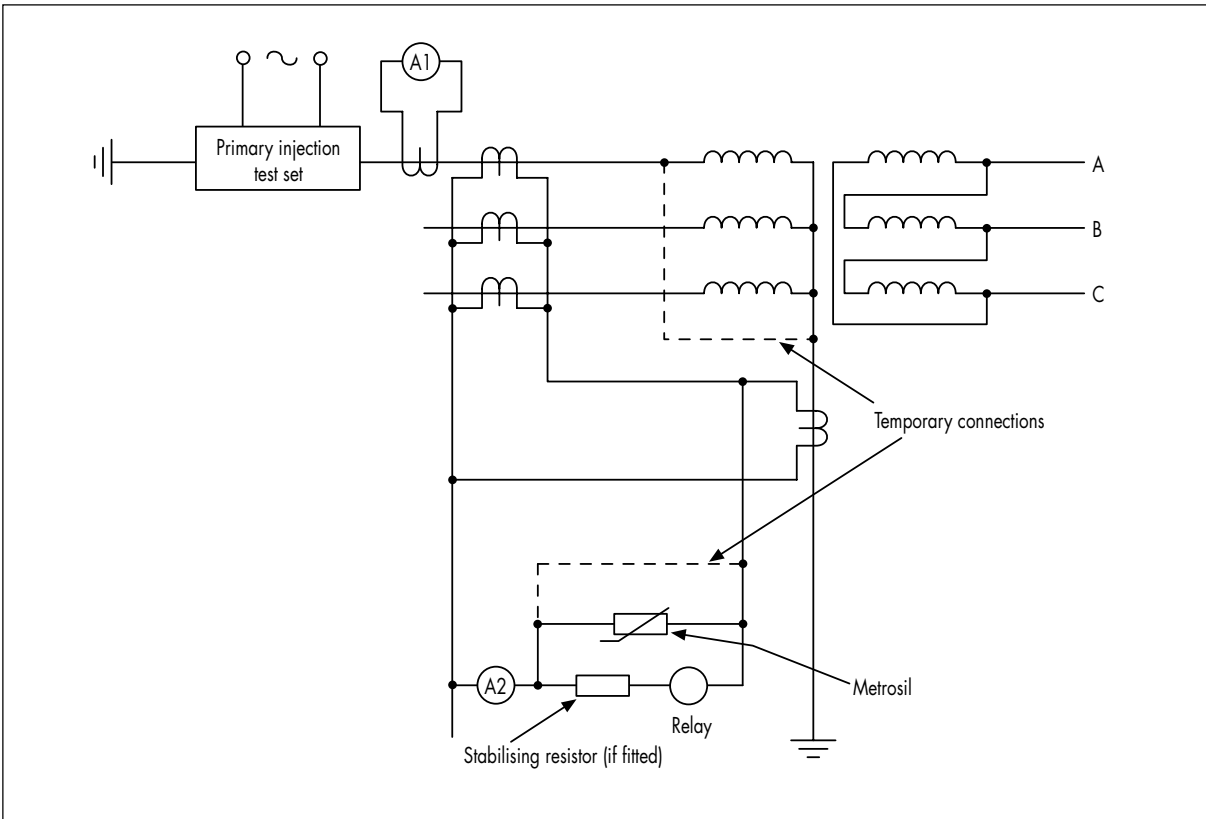

Figure 3 Stability check of restricted earth fault protection.

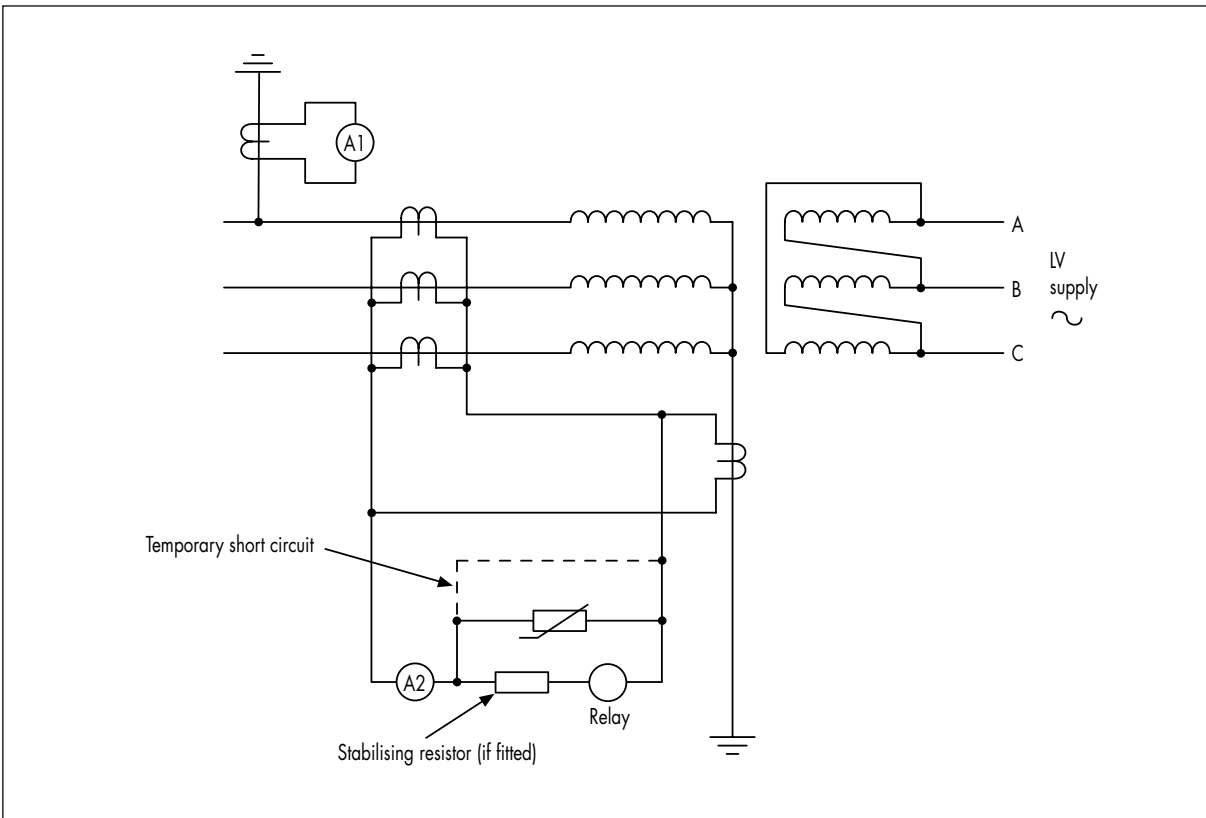

Figure 4 Stability check on restricted earth fault scheme by back energising with a low voltage supply.

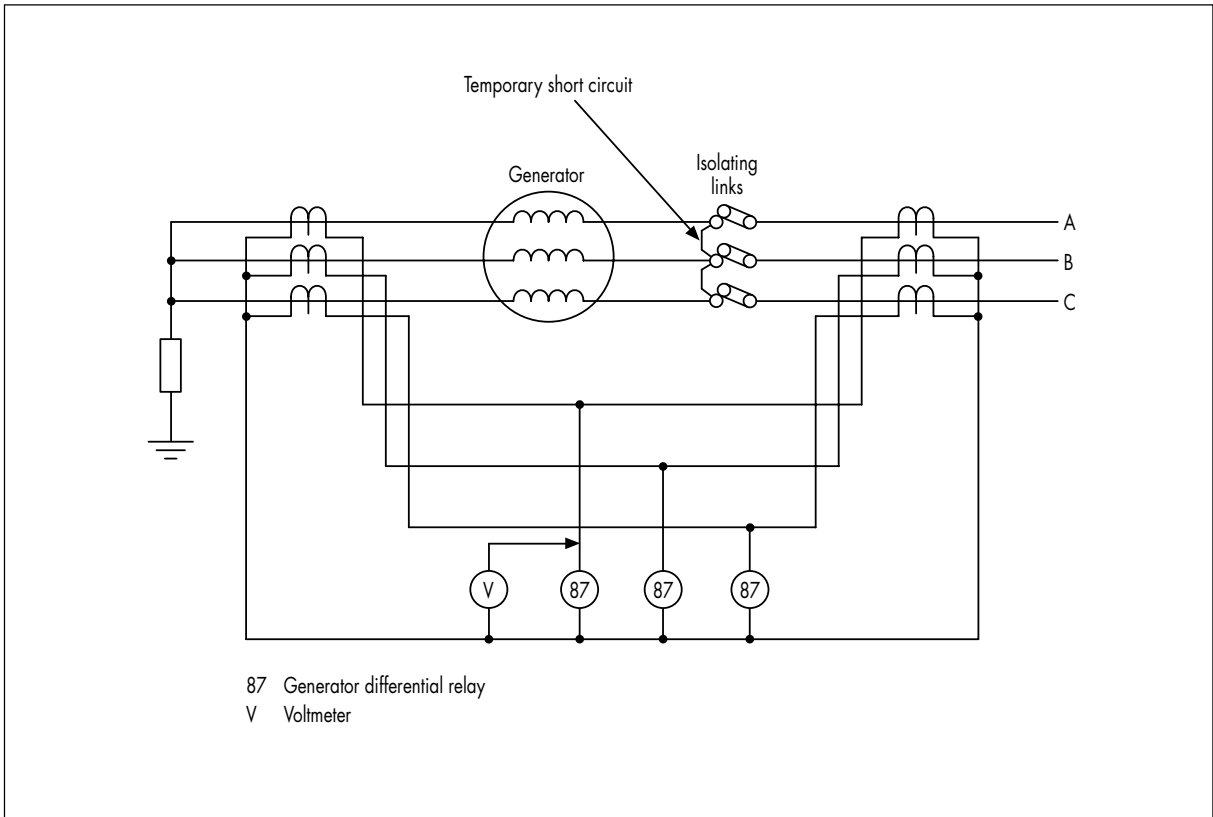

Figure 5 Testing sensitivity of generator differential protection using generator to supply primary current.

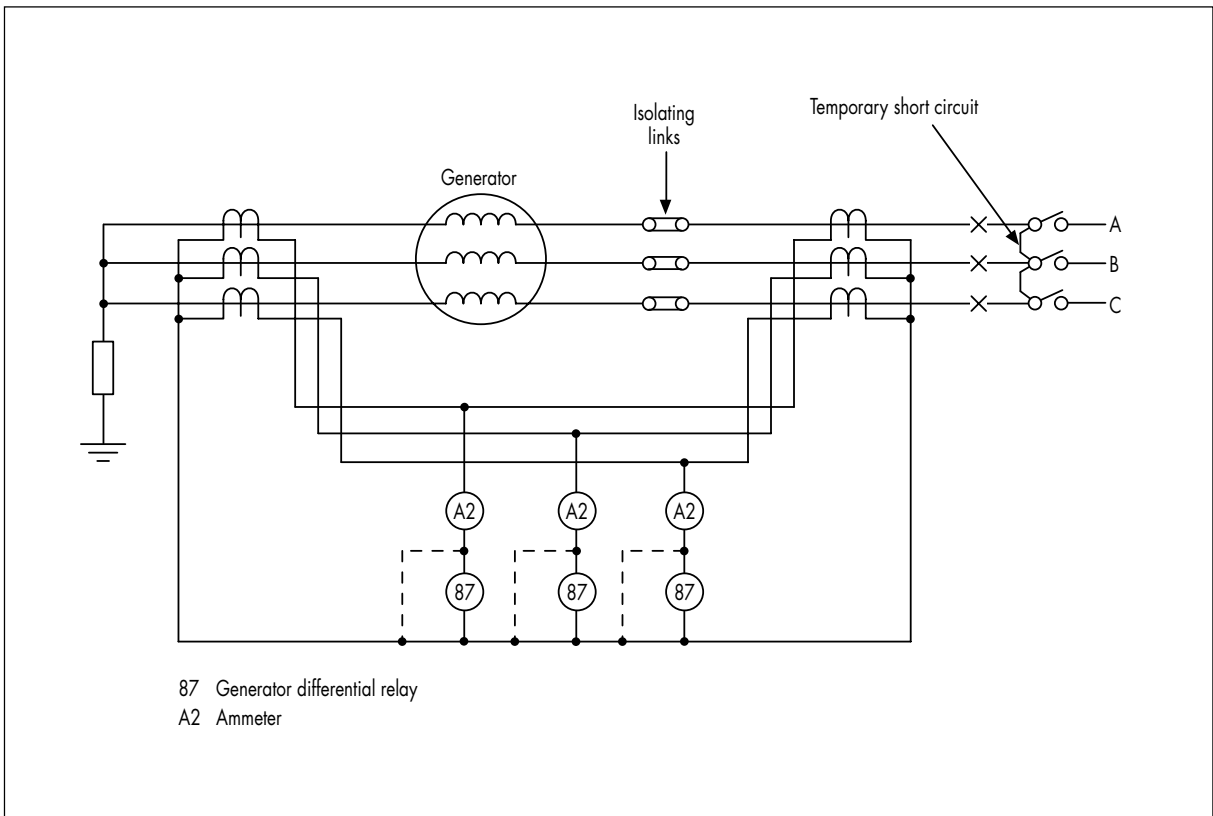

Figure 6 Checking stability of generator differential protection.

Section 3. MAINTENANCE

Periodic maintenance is not necessary. However, periodic inspection and test is recommended. This should be carried out every 12 months or more often if the relay is operated frequently or is mounted in poor environmental conditions.

- 3.1 Repeat secondary injection tests 2.2.4 to prove operation, with emphasis on contact wear and condition. Mechanical settings may be checked against those shown in Section 4.

Section 4. MECHANICAL SETTINGS

4.1 General

Armature gap measurements should be made with the top of the feeler gauge level with the centre line of the core.

Contact pressures are measured with a gramme gauge at the contact tips.

In general contact gaps and follow through are defined by quoting an armature gap at which the tips should be just closed or just open.

The relay contact state is always defined with the relay in the unenergised position, unless otherwise specified on the appropriate circuit diagram.

- 4.1.1 With the armature closed the clearance between the back of the armature and the back stop should be 0.003"/0.008".

- 4.1.2 Nominal armature gap open: 0.060" for all types.

Set screw in armature so that armature gap when closed is approximately 0.005"/0.010".

4.2 Contact settings

- 4.2.1 Normal duty make contacts

With the armature closed onto a 0.011" feeler gauge the make contacts should be closed, but should be open using a 0.013" feeler gauge.

Contact settings	2 contacts (MFAC 34)	4 contacts (MFAC 14)
Force to just close the make contacts	20/25 grams	15/20 grams
Force to just lift the fixed contact off its support	15/20 grams	20/25 grams

Nominal contact gap 0.060"/0.080"

4.3 Mechanical flag settings

- 4.3.1 Settings for self reset units

MFAC 14/34

With the armature closed on to a 0.013" feeler gauge the flag should be free to fall, but should not fall using an 0.018" feeler gauge. Adjustment is made to the catch spring on the flag.

Section 5. PROBLEM ANALYSIS

5.1 Failure to operate

Check diagram for correct input connections.

Check tap voltage; this is marked above or below the plug bridge on the front of the module.

Note: with the plug removed the relay setting goes to the highest tap value.

Measure the input current at V_s , this should be 38mA (excluding the metrosil).

Flag spring may be jammed between armature and core face, preventing armature closure.

Check internal wiring for damage.

Check choke continuity - resistance 240 ohms \pm 15%.

Check resistor values - remove pcb from module and fold down to gain access to board.

Setting range	Resistors on PCB ZJ0038
	R1 – R3 R5–R6 R7–R8 R9
15–185	680 Ω 680 Ω 150 Ω 120 Ω
Adjustable resistor	0–1000 Ω
Capacitor	3.3 μ F
Relay coil	190 Ω
Setting range	Resistors on PCB ZJ0038
	R1 – R6
25–175	1.3K Ω
25–327	2.4K Ω
Adjustable resistor RV1	510 Ω
Capacitor	C1 1.7 μ F \pm 5% 50Hz, 1.18 μ F \pm 5% 60Hz.
Relay coil	560 Ω \pm 15%
Setting range	Resistors on PCB ZJ0038
	R1–R6
100–400	2.7K Ω
	R9
	3.9K Ω

5.2 Output contacts not changing state

Check output terminals with reference to appropriate diagram.

Operating pushrods not in position

Internal wiring damaged

Contamination of contacts

Contacts should be cleaned with the burnishing tool supplied in the relay tool kits.

On no account should knives, files or abrasive materials be used.

Check mechanical settings as per Section 4.

Section 6. SPARES

When ordering spares, quote the full relay model number and any component reference numbers, or briefly describe the parts required.

Should the need arise for the equipment to be returned to Alstom Grid for repair, then the form at the back of this manual should be completed and sent with the equipment together with a copy of any commissioning test results.

Section 7. COMMISSIONING TEST RECORD

High Impedance Differential Relay Type MFAC

		Date	_____
Station	_____	Circuit.	_____
Relay Model No.	_____	Serial No.	_____
Setting range	_____	CT ratio	_____
Setting voltage	_____	Relay setting	_____
Type of ext. metrosil	_____	Shunt resistor ohms (if fitted)	_____
		Calculated primary operating current	_____

Test results

2.2.3 Relay CT shorting switch

2.2.4 Secondary voltage to operate relay.

Phase	Total current (A1)	Relay current (A2)	PU volts	DO volts
A				
B				
C				

Drop off / pick up ratio check

2.2.6 Primary current to operate relay

Phase	Primary current (A1)	Relay current (A2)	Relay voltage
A			
B			
C			
N			

2.2.7 Stability check by primary injection

Restricted earth fault

Phases	Primary current (A1)	Spill current (A2)
A-N		
B-N		
C-N		

Circulating current between two or more sets of current transformers.

Phases	Primary current (A1)	Spill current (A2)
A1-A2		
B1-B2		
C1-C2		

Where more than two sets of current transformers are involved, injection should be carried out between set 1 and each other set in turn.

Commissioning Engineer

Customer Witness

Date

Date

REPAIR FORM

Please complete this form and return it to Alstom Grid – SAS with the equipment to be repaired. This form may also be used in the case of application queries.

Alstom Grid – SAS
St. Leonards Avenue
Stafford
ST17 4LX
England

For : After Sales Service Department

Customer Ref: _____ Model No: _____
Alstom Grid _____ Serial No: _____
Contract Ref: _____
Date: _____

1. What parameters were in use at the time the fault occurred?

AC Volts _____ Main VT/Test set
DC Volts _____ Battery/Power supply
AC current _____ Main CT/Test set
Frequency _____

2. Which type of test was being used? _____

3. Were all the external components fitted where required? Yes / No
(Delete as appropriate)

4. List the relay settings being used

5. What did you expect to happen?

continued overleaf



6. What did happen?

7. When did the fault occur?

Instant	Yes / No	Intermittent	Yes / No
Time delayed	Yes / No	(Delete as appropriate)	
By how long?	_____		
	-		

8. What indications if any did the relay show?

9. Was there any visual damage?

10. Any other remarks which may be useful:

Signature

Title

Name (in capitals)

Company name



PUBLICATION: R8007G

